



EQUIPMENT TRAY ASSEMBLIES

Lighting &
Integrated Systems



ARINC 404 & 600 MOUNTING TRAYS AND ACCESSORIES

B/E Lighting & Integrated Systems specializes in standard ARINC 404 & 600 mounting trays as well as custom tray designs providing the flexibility needed to accommodate your system requirements.

Our trays are available individually or as part of an Avionics Support Package (ASP) Kit with ARINC rack connector; Mil-Spec connectors, pin, sockets and backshells; tray mounting rails; and connector mounting hardware.

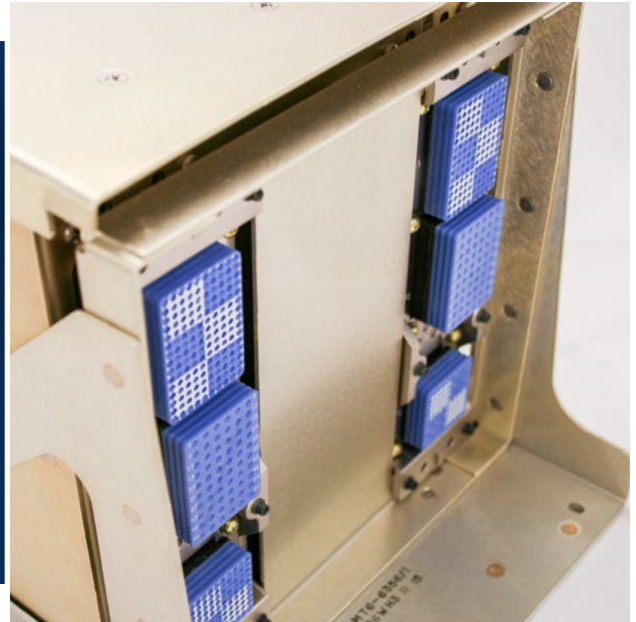

TECHNICAL SPECIFICATIONS

B/E Lighting & Integrated Systems' ARINC 404 and 600 equipment trays are designed to accommodate standard mounting hole shelf locations per ARINC or OEM specifications. Front holddown locations and other dimensions are also per ARINC specifications.

TRAY WIDTH

MCU	2	3	4	5	6	7	8	10	12
ATR	1/4	3/8	1/2	-	3/4	-	1	-	1-1/2
# Mounting Holes	2	3	3	3	3	4	5	5	7
Distance b/n Mounting Holes	1.312"	1.312"	1.968"	2.264"	3.280"	2.624"	Inner: 2.264" Outer: 1.968"	Inner: 3.280" Outer: 2.624"	Inner: 2.264" Outer: 1.968"

TRAY LENGTH

	Overall Length	Mounting Hole Spacing
Long Tray Shell	20.08" (510.03mm)	18.01" (457.45mm)
Short Tray Shell	14.95" (379.73mm)	12.875" (327.03mm)

MECHANICAL ENGINEERING

Our custom designed mechanical trays are engineered according to specific applications per OEM installation manuals or other guidelines. Designs can be tested, qualified, and FAA certified as required.

- 3D solid modeling using SolidWorks, CADKey, AutoCAD, CATIA
- Structural analysis
- Environmental qualification testing
- Custom designs: low profile, military, specialty, ruggedized, racking units for ARINC 404/600, RTCA-DO160, MIL-STD-810, Boeing, Airbus standards.





LRU COOLING REQUIREMENTS

For LRUs with cooling requirements, our trays support convection air flow, aircraft forced air cooling, and forced air cooling requiring a fan.

CONVECTION AIR FLOW

An LRU without external forced air cooling may require a tray shell with an oval cutout to optimize air flow to cool the LRU.

FORCED AIR COOLING

Metering Plates & Seals—Air inlet holes in the metering plate allow for air flow regulation. Metering plate seals and baffle plugs (plug bumpers) are supplied with each tray assembly for insertion by the customer to direct air flow as required. For assemblies requiring a fan, we also provide an open metering plate or seal retainer for maximum air flow.

Fan Assemblies & Filters—Our equipment trays are designed with options for rear, side or bottom mounted fans and meet ARINC 600 Level (1) or Level (2) cooling requirements. Our fan filter provides high efficiency and low resistance without reducing fan velocity or airflow. The assembly is flame retardant per 8110-3 FAR 25.853 Appendix "F" Part 1(a)(v) and meets ARINC 600-12 ITM 3.5.4.4 Coolant Air Quality requirements. Filter elements are replaceable.

Air Plenum Chambers—Trays requiring a fan also require a plenum. Our plenums are fastened with corrosion-resistant locking clinch nuts and screws. MIL-A-46146 RTV adhesive/sealant is applied to form an airtight seal.

<p>Material Specifications</p> <ul style="list-style-type: none"> • Aluminum alloy: 5052, 6061, or 2024 • Stainless steel, 300 Series, 17-4 PH standard • Silicone, SC-1021V Red 56 durometer 	<p>Finish</p> <ul style="list-style-type: none"> • Gold chem-film per MIL-DTL-5541, Type 1, Class 1A • Other finishes available by request <p>Part Marking</p> <ul style="list-style-type: none"> • Per MIL-STD-130
---	--

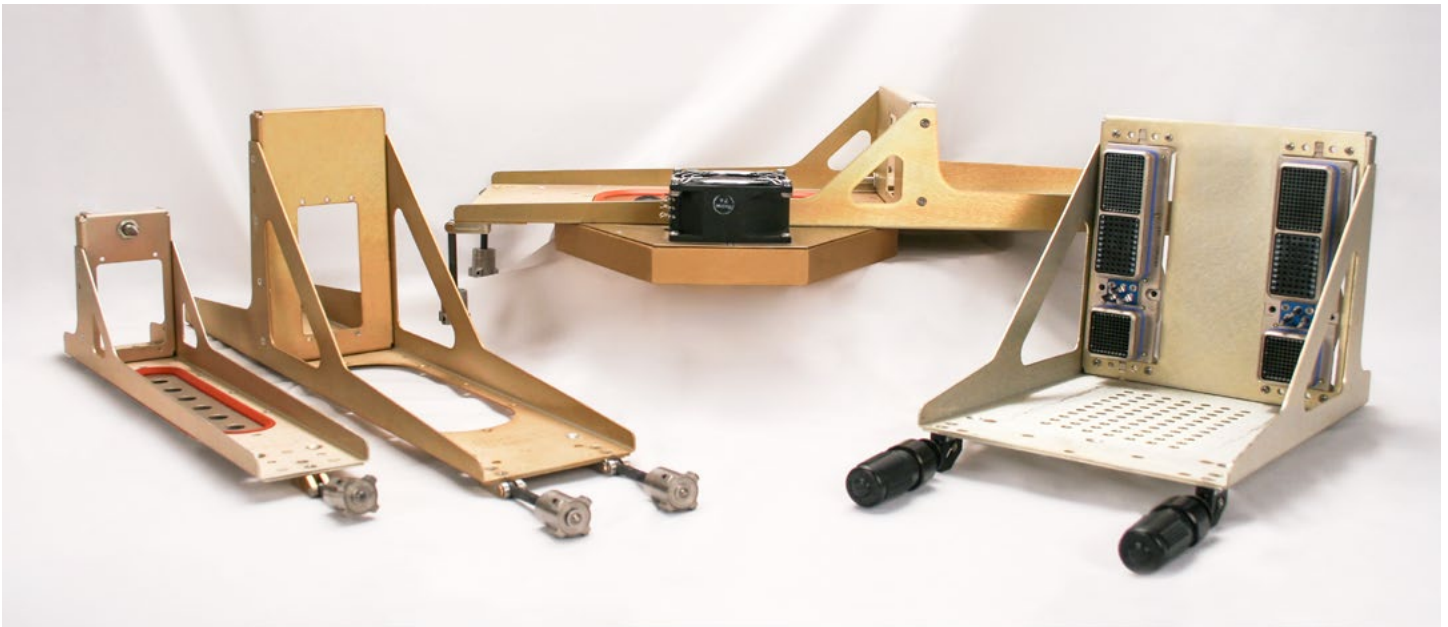

ARINC 404 ASSEMBLIES

Tray Style (ATR)	W= Inside Width (mm)	H= Inside Height (mm)	ARINC 404 Connector Series
1/4	2.39" (60.75)	4.36"/6.88" (110.75/174.75)	DPXA, DPXB, DPX2, DPX3
3/8	3.69" (93.72)	4.36"/6.88" (110.75/174.75)	DPXA, DPXB, DPX2, DPX3
1/2	5.01" (127.30)	4.36"/6.88" (110.75/174.75)	DPXA, DPXB, DPX2, DPX3, DPX4
3/4	7.63" (193.29)	4.36"/6.94" (110.75/176.35)	DPXA, DPXB, DPX2, DPX3, DPX4
1	10.26" (259.33)	4.36"/6.94" (110.75/176.35)	DPXA, DPXB, DPX2, DPX3, DPX4
1-1/2	15.40" (391.28)	4.36"/6.94" (110.75/176.35)	DPXA, DPXB, DPX2, DPX3, DPX4

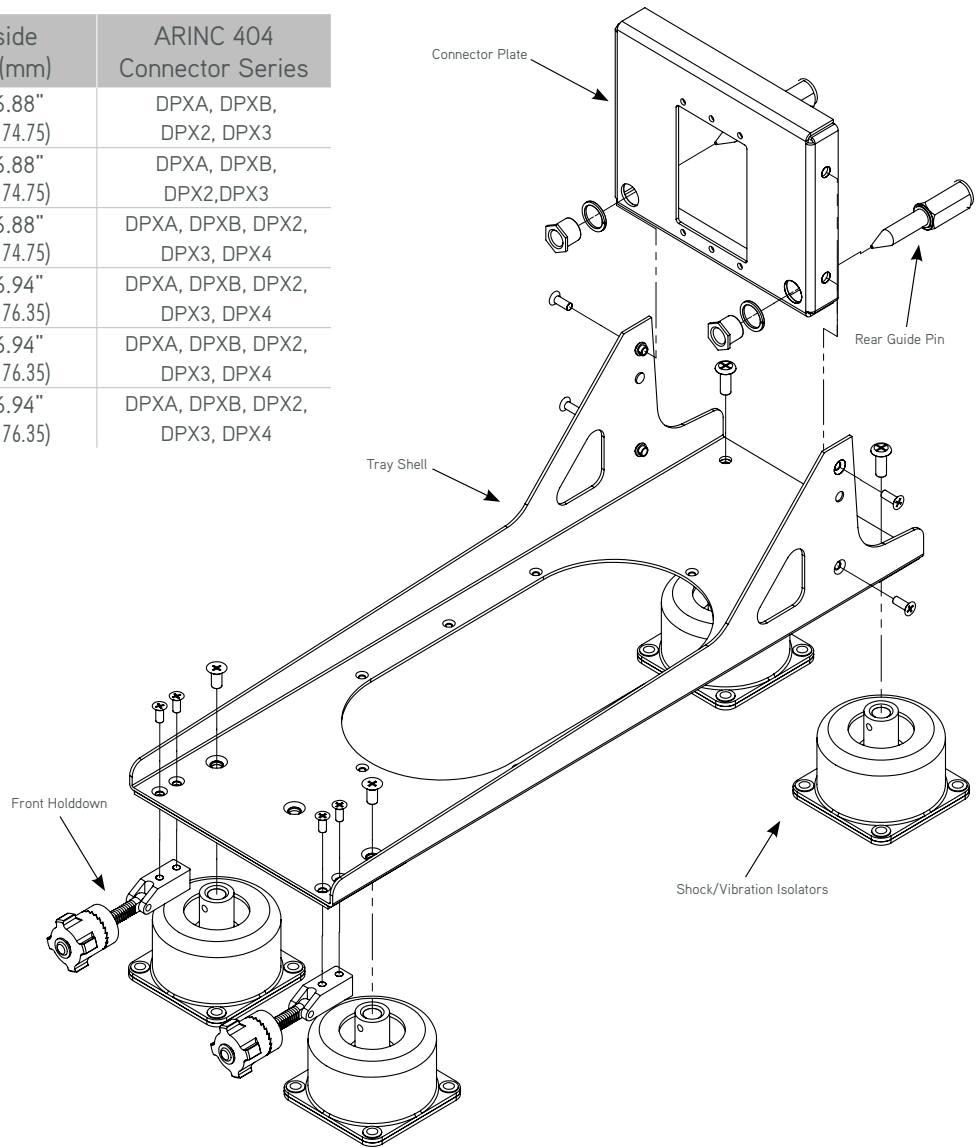

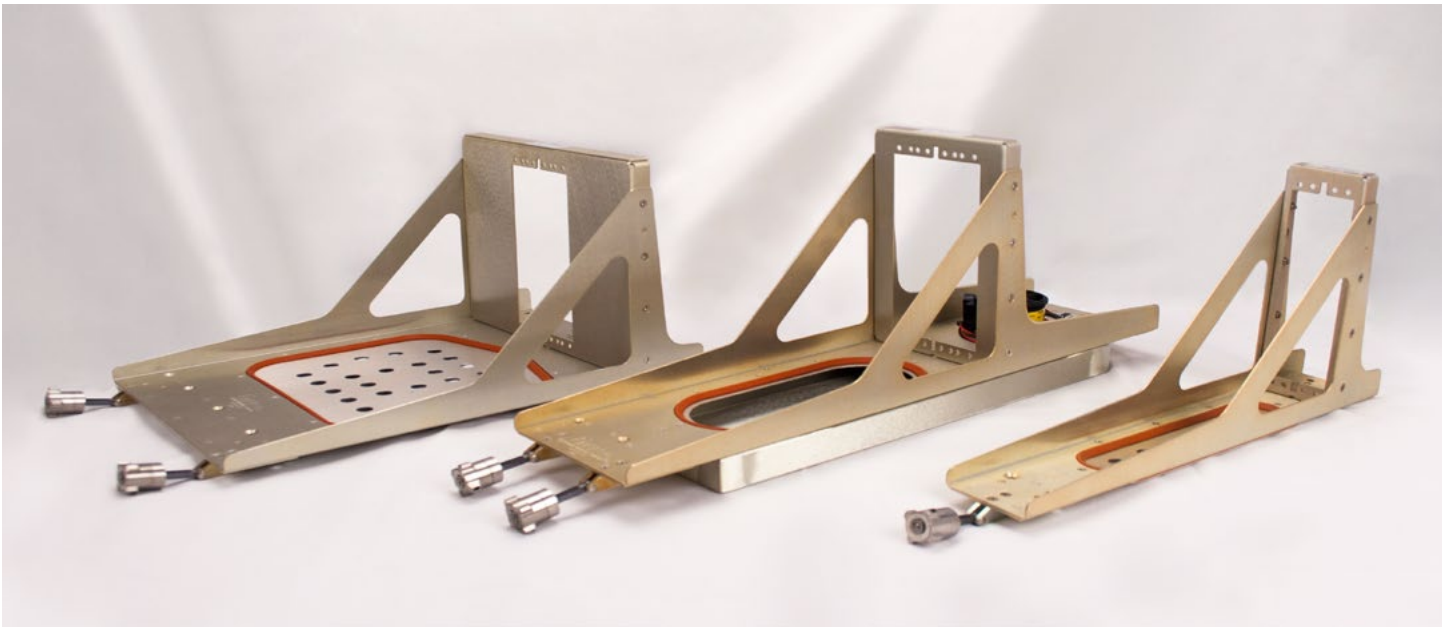

ARINC 600 ASSEMBLIES

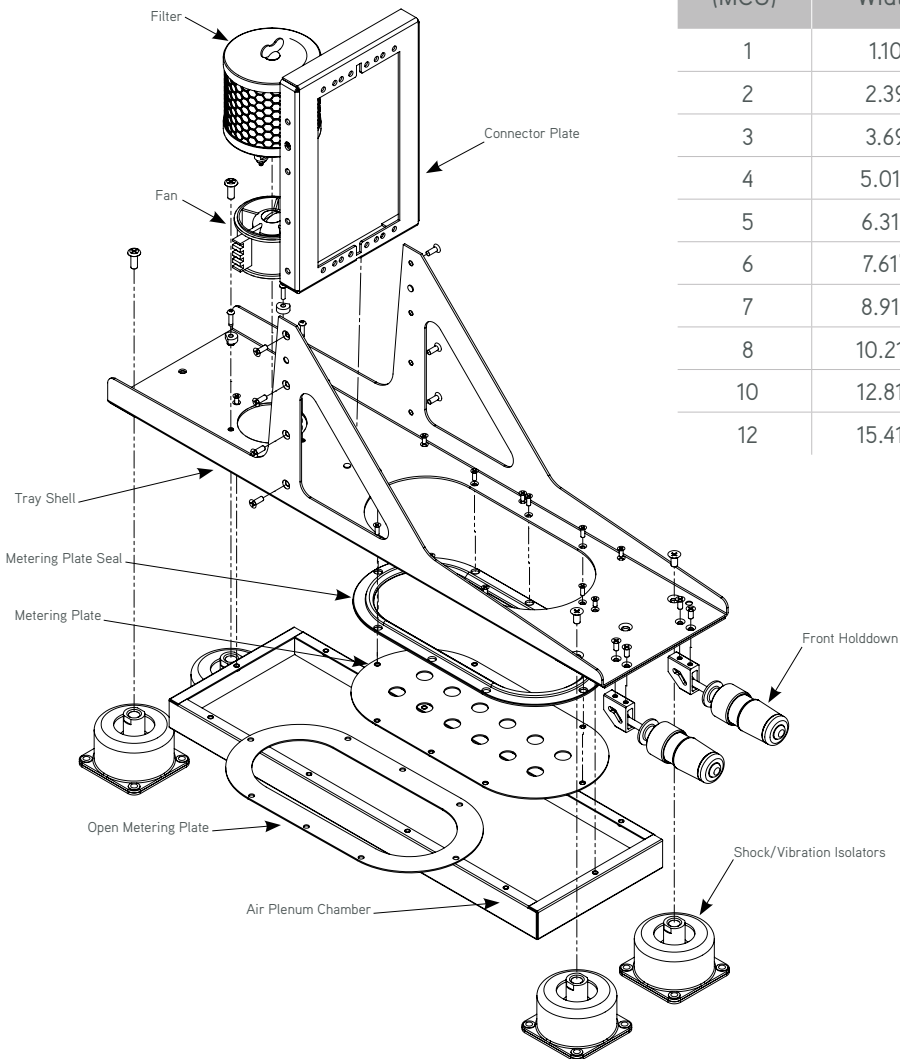

Tray Style (MCU)	W= Inside Width (mm)	H= Inside Height (mm)	ARINC 600 Connector Series
1	1.10" (27.94)	7.30" (185.42)	Size 1
2	2.39" (60.75)	7.30" (185.42)	Size 1, 2
3	3.69" (93.72)	7.30" (185.42)	Size 1, 2
4	5.01" (127.30)	7.30" (185.42)	Size 1, 2, 3
5	6.31" (160.27)	7.30" (185.42)	Size 1, 2, 3
6	7.61" (193.29)	7.36" (186.9)	Size 1, 2, 3
7	8.91" (226.31)	7.36" (186.9)	Size 1, 2, 3
8	10.21" (259.33)	7.36" (186.9)	Size 1, 2, 3
10	12.81" (325.37)	7.36" (186.9)	Size 1, 2, 3
12	15.41" (391.41)	7.36" (186.9)	Size 1, 2, 3



MECHANICAL COMPONENTS

SHOCK/VIBRATION ISOLATORS

With many shock and vibration isolator styles in stock, we can cross-reference part numbers to ensure prompt delivery. Features include:

- Effective vibration isolation in all axes
- Compact design
- Standardized sizes & products for most applications
- Customization to meet specific requirements
- Supports static loads from 1 to 80lbs
- Engineering support beginning with selection analysis



GUIDE PINS

Guide Block (MT1-6002)	Guide Block (MT1-6062)	Panel Mounted (MT1-5003)
<ul style="list-style-type: none"> • Heavy duty block design • Spring loaded guide feature 	<ul style="list-style-type: none"> • Heavy duty block design • Optional stainless steel material • Solid pin design 	<ul style="list-style-type: none"> • Rear panel required • Spring loaded guide feature

HOLDDOWNS

Torque limiting holddown (MT1-5005)	Self-locking holddown (MT1-5001)	Thumb-screw holddown (MT1-5028)
<ul style="list-style-type: none"> • Designed to ARINC 600 specifications to prevent over-torquing • Insertion & extraction features • Flame retardant plastic 	<ul style="list-style-type: none"> • Adjustable torque • Standard M85731 body • Riveted construction 	<ul style="list-style-type: none"> • Smaller profile • Non-ratcheting wave spring locking mechanism • Riveted construction

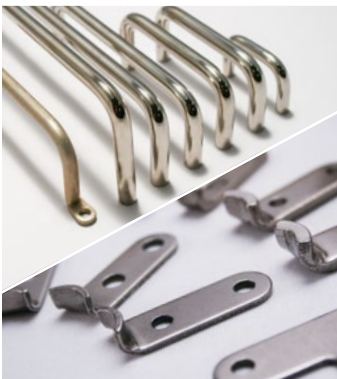
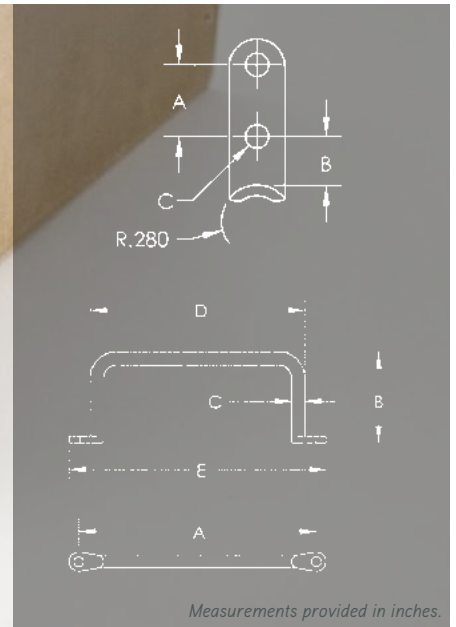

ACCESSORIES

Our product line includes hooks and handles; rack connectors are sold outright or as part of ASP Kits.

HANDLES

- Used to install or remove LRU
- Installed onto front plate

P/N	A	B	C	D	Thread
MT1-HDL-4	1 1/2	1 1/8	1/4	1 3/4	6-32 X 3/8
MT1-HDL-4A	2 13/16	1 1/2	5/16	3 1/8	6-32 X 3/16
MT1-HDL-5	3	1 1/2	5/16	3 5/8	8-32 X 3/16
MT1-HDL-6	4 1/2	1 1/2	5/16	4 13/16	8-32 X 3/16
MT1-HDL-7	6 1/2	1 3/4	5/16	6 13/16	10-32 X 3/16
MT1-HDL-8	9 1/4	2 1/4	5/16	9 7/16	10-32 X 3/16

P/N	A	B	C	D	E
MT1-HDL-2*	4 1/2	1 19/32	1/4	4 1/16	4 7/8

Material: Brass, 410 Series; Finish: Nickel Plated

*Material: Alum, 110 Series; Finish: Gold Chem Film

HOOKS

- Secures LRU to mounting tray
- Mounts onto front plate
- Holddown latches onto j-hook

P/N	A	B	C	Max Loading / hook (lbs)
MT1-HDH-1*	.562	-	.182	20 & Below
MT1-HDH-2*	.562	-	.182	Above 20
MT1-HDH-3	.562	.375	.182	20 & Below
MT1-HDH-3EP	.562	.500	.182	20 & Below
MT1-HDH-3SP	.687	.265	.156	20 & Below
MT1-HDH-3-228	1.50	.335	.156	20 & Below
MT1-HDH-4	.562	.375	.182	Above 20
MT1-HDH-4EP	.562	.437	.182	Above 20
MT1-HDH-4SP	.687	.265	.182	Above 20

Rated to 125000 PSI, Passivate, MIL-C-172B
& ARINC 404/600. Material: SS 410 *Material: SS304



RUGGEDIZED TRAYS

B/E Lighting & Integrated Systems designs ruggedized trays to meet higher Environmental Testing Conditions. These trays are ideal for environments with higher vibration and meet increased crash safety.

- Higher yield strength materials
- Increased bend radii throughout & doubler plate thickness
- Complete riveted construction
- Additional rear doubler with improved support features
- Improved connector plate features

ORDERING GUIDES

ARINC 404 CONFIGURATION GUIDE (ATR)

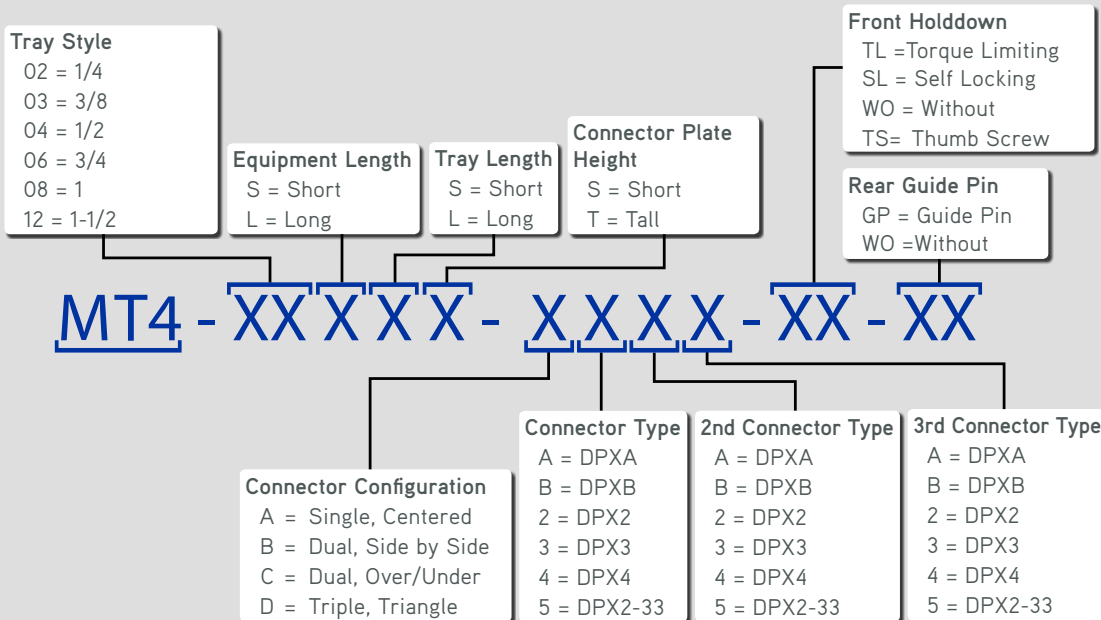

Contact us if fan or shock vibration isolators are required. B/E part number will be generated based on configuration selected.

ARINC 600 CONFIGURATION GUIDE (MCU)

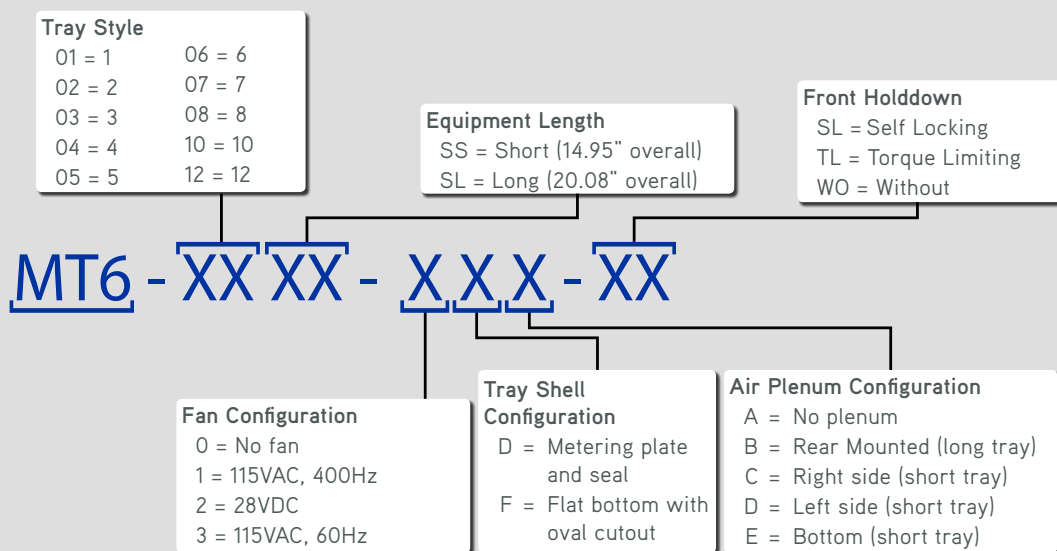

Contact us if fan or shock vibration isolators are required. B/E part number will be generated based on configuration selected.

Lighting &
Integrated Systems



beaerospace.com/LIS ■ +1 262.679.6170